



SKYLINE  WINDOWS

**500 Series Window Wall**

FIXED / CASEMENT / DUAL ACTION



## WINDOW WALL

Window wall systems are glazing that is traditionally framed from slab to slab and employ a sill tank or receptor for drainage as well as a head receptor to accommodate live-load movement of the building structure. Window wall systems are commonly used in ribbon window configurations or punched openings.

### BENEFITS

- **IMPROVED SITE LOGISTICS**
- **SPEED OF INSTALLATION**
- **HORIZONTAL INSTALLATION PROVIDES COMPLETE ENCLOSURE FLOOR BY FLOOR**
- **REDUCED MATERIAL & LABOR COST VERSUS TRADITIONAL BY-PASS CURTAINWALL SYSTEMS**
- **DESIGN FLEXIBILITY**
- **COMPARTMENTALIZATION SLAB TO SLAB IMPROVES ACOUSTIC PERFORMANCE**
- **EXCELLENT AIR, WATER & THERMAL PERFORMANCE**
- **SUPERIOR QUALITY CONTROL VERSUS SITE BUILT SYSTEMS**
- **FLOOR EDGE SLAB COVERS, IN EITHER METAL OR GLASS, CAN BE USED FOR THE AESTHETIC OF A CONTINUOUS SLAB BY-PASS CURTAINWALL AT A SIGNIFICANTLY REDUCED COST**

## 500 SERIES WINDOW WALL

Skyline Windows' 500 Series of window wall products offer a variety of depth and configurations to meet each project's aesthetic and performance needs with combinations of fixed lights, in-swing vents and/or dual action (tilt & turn) vents as required by design. Skyline Windows' 1700 Series Terrace Doors and 2000 Series Lift & Slide doors can be seamlessly incorporated into the window wall system to provide access to balconies, terraces, or roof-top amenity spaces.

### BENEFITS

- **STRUCTURAL GLAZING FOR LONG-TERM DURABILITY**
- **PRESSURE EQUALIZED FRAME DESIGN**
- **EUROPEAN MULTI-LOCK HARDWARE & CENTER "GOOSE-NECK" GASKET DESIGN**
- **KEY-CAPTURE HANDLE THAT COMBINES CHILD-FALLS PROTECTION & MAINTENANCE OPERATION**
- **WIDE VARIETY OF STANDARD & CUSTOM HANDLE DESIGNS AVAILABLE**
- **MULTIPLE STANDARD & PROFILED SIGHTLINES TO MEET PROJECT'S DESIGN INTENT**
- **HIGH PERFORMANCE, DURABLE ARCHITECTURAL FINISHES**
- **INTEGRATED TERRACE DOORS DESIGNED AS PART OF OVERALL SYSTEM**

*Contact Skyline Windows to discuss the full range of standard and custom design options available.*



The NOMA | 50 W 30th  
New York, NY

**U.S.  
JEWELRY**

IMPORTS &  
WHOLESALE

T. 212-219-1272  
F. 212-725-8693

800 6AVE

**NOVELTY  
CANDY STORE**

CIGARETTES & CANDY

W 30 St



# REPRESENTATIVE DETAILS

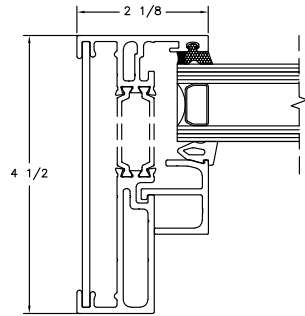

FIXED JAMB

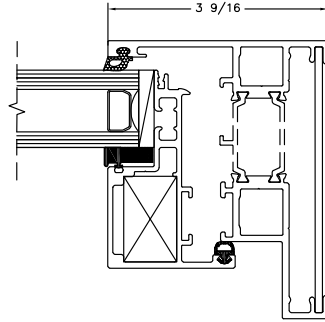

OPERABLE JAMB

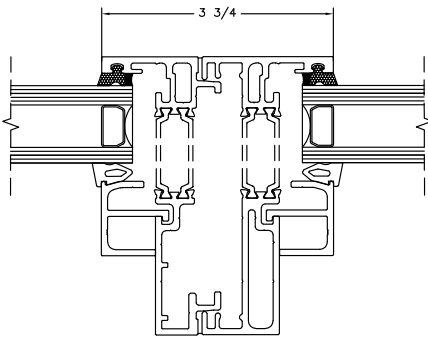

FIXED/FIXED  
STACKED MULLION

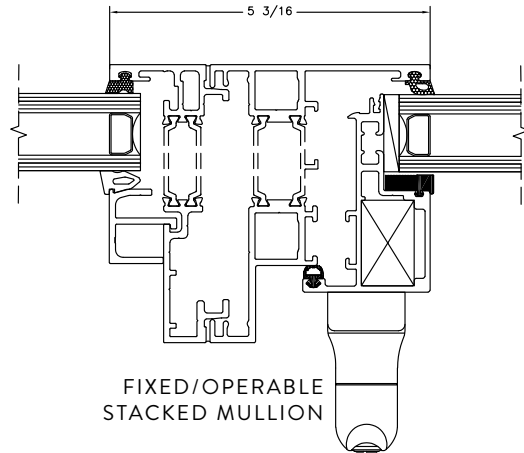

FIXED/OPERABLE  
STACKED MULLION

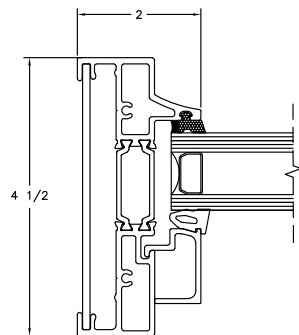

FIXED JAMB  
ALTERNATE FRAME DESIGN

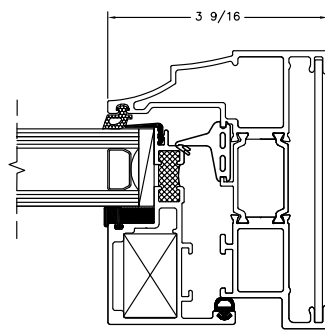

OPERABLE JAMB  
ALTERNATE FRAME DESIGN

## SKYLINE WINDOWS 500 SERIES WINDOW WALL

*Details shown are representative. Skyline Windows has an extensive library of standard and custom design options to meet virtually any aesthetic or performance requirements. Contact Skyline Windows to develop site specific details to meet your project needs.*

# SLAB EDGE COVERS

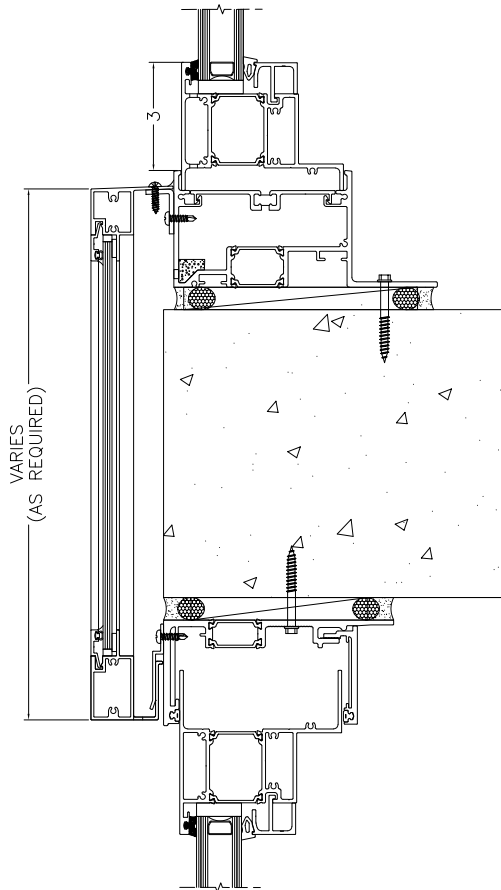

GLASS SLAB  
EDGE COVER

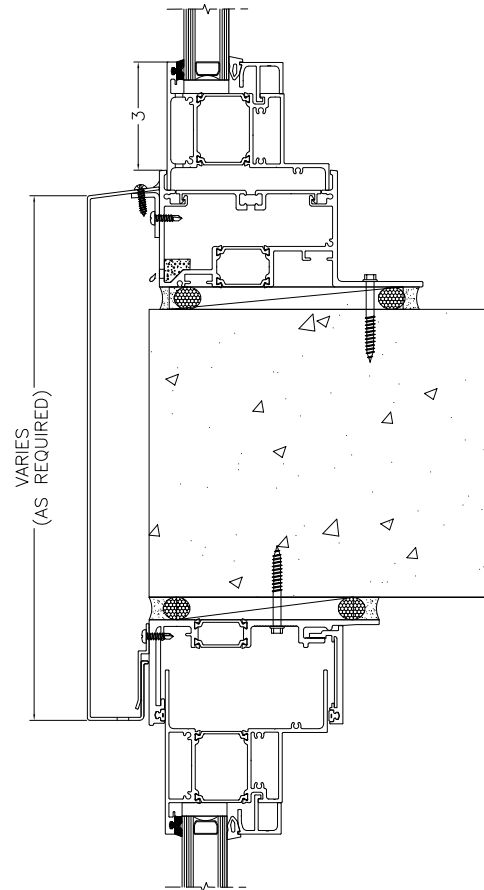

METAL SLAB  
EDGE COVER

*Details shown are representative. Skyline Windows has an extensive library of standard and custom design options to meet virtually any aesthetic or performance requirements. Contact Skyline Windows to develop site specific details to meet your project needs.*

Skyline Windows' 1700 Series Terrace Doors and 2000 Series Lift & Slide Doors seamlessly integrate with the 500 Window Wall to create a complete system. Contact Skyline Windows to see our complete library of integrated door details.



The Sutton | 959 First Avenue  
Glass Slab Edge

# OUTSIDE CORNER DETAILS

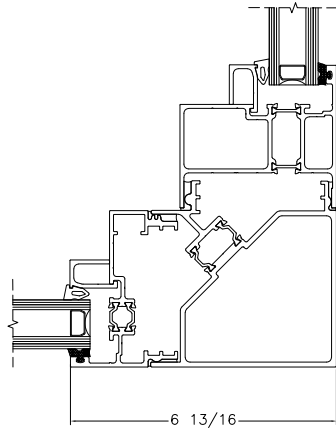

TYPICAL CORNER MULLION

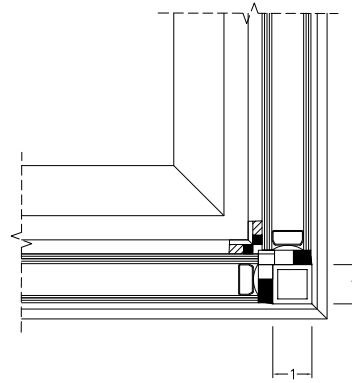

GLASS TO GLASS CORNER

## Representative Details

All details shown are representative. Contact Skyline Windows to develop site specific details that meet your project needs.

SKYLINE 500 SERIES WINDOW WALL PRODUCTS

## PERFORMANCE



SYSTEM DEPTH  
3.25", 4" or 4.5"



WATER RESISTANCE  
ASTM E331 - 15PSF  
ASTM E547 - 15PSF



U FACTOR  
0.45 - 0.26\*



AIR INFILTRATION  
ASTM E 283  
< 0.01 CFM / ft<sup>2</sup>  
@ 6.24 PSF



ACOUSTIC  
Tested to OITC of 36\*  
STC of 41



AAMA RATING  
AW-PG100

\* These values are for reference only; U Factors & Acoustic results are highly dependent on the glass make-up selected. Consult with Skyline Windows for project specific results.





One South First | Brooklyn, NY

OUR LEGACY

# A BRIEF LOOK INTO OUR HISTORY

Quality, innovation and customer service have been the guiding principles of Skyline Windows since Sam Kraus founded it as a roofing and waterproofing business in 1921. As Skyline evolved, the dedication to craftsmanship and service was passed down from generation to generation.

In the 1950s, under the direction of Sam's son, David Kraus, Skyline entered the window replacement business, then a new and burgeoning industry. Eventually, Skyline began manufacturing our own window systems to meet the expectations for high quality and performance that our customers demanded.

When third generation and current Chairman of the Board Steven Kraus came to Skyline in the 1970s, he moved the company into new and broader product offerings. The integration of state-of-the-art European hardware systems and development of historic replacement window designs are hallmarks of the innovations seen under his stewardship. Fourth generation and current CEO, Matt Kraus, is poised to lead Skyline Windows into the future.



1921

Sam Kraus establishes his business as a roofing & waterproofing company

David Kraus expands the business & begins installing replacement windows

1950s



1960s

Establishment of New York City's Landmarks Preservation Commission & start of the historic window replacement business

Skyline begins manufacturing windows that incorporate quality craftsmanship & custom detailing

1970s



1990s

In order to meet market demands, Skyline purchases a new manufacturing plant

Skyline's headquarters moves to current location - Bronx, NY

2000s



2014

Skyline purchases a second production facility, providing over 100,000 square feet of manufacturing space

Skyline Windows celebrates 100 years in business!

2021



## REPRESENTATIVE PROJECT PORTFOLIO

*Skyline Windows offers a wide variety of window and door products for new construction, replacement, repositioning and historic retrofit markets. The following is a representative sampling of those other products and applications.*



### **170 Amsterdam**

*Project Type*  
RESIDENTIAL

*Product*  
WINDOW WALL

*Construction Type*  
NEW CONSTRUCTION



### **675 Third Avenue**

*Project Type*  
COMMERCIAL

*Product*  
IN-SWING CASEMENTS

*Construction Type*  
GUT REHAB



### **Chrysler Building**

*Project Type*  
HISTORIC LANDMARK

*Product*  
DOUBLE HUNG  
WINDOWS

*Construction Type*  
OCCUPIED RETROFIT

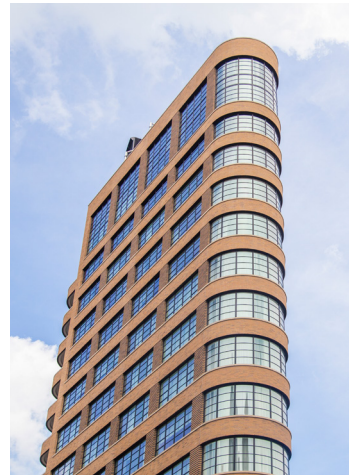

### **10 Sullivan**

*Project Type*  
RESIDENTIAL

*Product*  
OUTSWING CASEMENTS  
WINDOW WALL  
TERRACE DOORS

*Construction Type*  
NEW CONSTRUCTION



### **99 High Street Boston, MA**

*Project Type*  
LANDMARK RETROFIT  
/COMMERCIAL

*Product*  
CUSTOM  
WINDOWS

*Construction Type*  
GUT REHAB



### **Rockefeller Apartments**

*Project Type*  
RESIDENTIAL

*Product*  
OUTSWING  
CASEMENTS

*Construction Type*  
OCCUPIED RETROFIT

ADDRESS  
220 East 138th Street  
Bronx, NY 10451

PHONE  
(212) 491-3000

WEBSITE  
[skylinewindows.com](http://skylinewindows.com)

